

A novel mutation in DAX1 gene causing different phenotypes in three siblings with adrenal hypoplasia congenita

L.E.P. Calliari, C.A. Longui, M.N. Rocha, C.D.C. Faria,
C. Kochi, M.R. Melo, M.B. Melo and O. Monte

Unidade de Endocrinologia Pediátrica,
Departamento de Ciências Fisiológicas, Faculdade de Ciências Médicas,
Santa Casa de São Paulo, São Paulo, SP, Brasil
Corresponding author: L.E.P. Calliari
E-mail: caliari@uol.com.br

Genet. Mol. Res. 6 (2): 277-283 (2007)
Received November 8, 2006
Accepted January 26, 2007
Published May 10, 2007

ABSTRACT. Adrenal hypoplasia congenita (AHC) is a rare disease that can be caused by many abnormalities, including an X-linked form. Mutations in the DAX1 gene have been assigned as the genetic cause of AHC. We describe here three siblings with AHC, clinically presented at different ages, two in the neonatal period and one oligosymptomatic during infancy. Molecular analysis was able to detect a novel mutation in exon 1 of the DAX1 gene, consisting of a transition of C to T at position 359, determining a stop codon at position 359 (Q359X). The mutated gene encodes a truncated protein missing a large portion of the ligand-binding domain (C-terminal domain). The recognition of the disease in the index case suggested the diagnosis in the other siblings. Interestingly, the same mutation is presented with different phenotypes, suggesting that first-degree family members of patients with DAX1 mutations should be carefully evaluated routinely.

Key words: Adrenal insufficiency, DAX1, Point mutation

INTRODUCTION

Congenital adrenal insufficiency cannot be considered rare in children, and is estimated to have an incidence of 1 in 12,500 births (Guo et al., 1996). Non-specific symptoms can initiate in the first days of life or late in childhood; therefore, the disease may not be easily detected, delaying diagnosis and treatment. Congenital adrenal insufficiency can be caused by congenital adrenal hyperplasia, but other rare diseases can be present, such as X-linked adrenal hypoplasia congenita (AHC) due to mutations in the DAX1 gene (Muscatelli et al., 1994; Zanaria et al., 1994).

The DAX1 gene (dosage-sensitive sex reversal-adrenal hypoplasia congenita critical region on the X chromosome) is located at Xp21.3 region, and encodes an unusual orphan member of the nuclear hormone receptor superfamily. All DAX1-described mutations alter the protein carboxy-terminal domain (ligand-binding domain) and impair the properties of bearing transcriptional repressor activity. This gene acts as a transcriptional repressor of genes involved in the steroidogenic pathway (Zanaria et al., 1994). Several mutations have been described in this gene, leading mainly to AHC, but also to hypogonadotropic hypogonadism. The phenotype of the patients with different mutations is variable, and the presentation can occur in the newborn, during childhood or even in adult life (Nakae et al., 1996).

In the present report, we describe a family with three siblings suffering from primary adrenal insufficiency due to adrenal hypoplasia congenita, where a novel DAX1 gene mutation was detected. Recognition of the mutation is of practical importance because it shows a genetic pattern of transmission, giving the possibility of finding new cases, even in oligosymptomatic individuals.

PATIENTS AND METHODS

Patients

Case 1 - Index case - MRD, date of birth - March 13, 2000.

First symptoms were at 30 days of life - dehydration and vomiting -, leading to hypovolemic shock, requiring endotracheal intubation and 15 days of intensive care. He was misdiagnosed and treated as renal tubular acidosis, using sodium bicarbonate and Sorcal®. Until the age of 3 ½ years, he was an overall hypoactive boy, requiring several hospital admissions, generally due to simple diseases such as tonsillitis after which he was discharged after intravenous saline infusion.

After 3 ½ years he started to develop skin hyperpigmentation, and the laboratory profile showed: Na = 133 mEq/L, K = 5.5 mEq/L, ACTH = 18,000 pg/mL (10-60 pg/mL - chemoluminescence), cortisol = 1.0 µg/dL (5.4-25 µg/dL - RIA). These data confirmed primary adrenal insufficiency, and combined treatment with hydrocortisone acetate and fludrocortisone was initiated, which alleviated hypoactivity and hyperpigmentation.

Case 2 - RRD, date of birth - November 8, 2003.

During the investigation of the index case, the mother was pregnant and a male neonate was born. He developed jaundice in the first days of life and received blood transfusion. At 29 days of life, he had a mild weight loss and dehydration and, due to his brother's diagnosis, he

was immediately investigated, showing topical testis and the following laboratory results: Na = 114 mEq/L, K = 5.8 mEq/L, ACTH = 560 pg/mL (10-60 pg/mL - chemoluminescence), cortisol = 11.0 µg/dL (5.4-25 µg/dL - RIA), aldosterone = 6.0 ng/dL (1-16 ng/dL - RIA), renin = 81 ng/mL (0.3-0.7 ng/mL - RIA). Primary adrenal insufficiency was then diagnosed. He was admitted to an intensive care unit and glucocorticoid and mineralocorticoid treatment was initiated, with adequate recovery.

Case 3 - MRD, date of birth - June 17, 1995.

After the diagnosis of the two younger brothers, the investigation of the older one (8 years old) was performed. The mother had no notable complaints about him, except that he was a shy and hypoactive boy, with a very mild skin hyperpigmentation. In the first 3 months of life, he had repeated fever episodes (5 "urinary tract infections" with negative cultures), treated with prophylactic sulfa up to two years of age due to a mild vesico-urethral reflux. He was an easily fatigable boy and had no physical activity even at school. On physical examination, we found mild gingival and skin pigmentation and topic testis. BP: 100/60 mmHg. Laboratory data showed Na = 133 mEq/L, K = 3.8 mEq/L, ACTH = 4000 pg/mL (10-60 pg/mL - chemoluminescence), cortisol = 3.9 µg/dL (5.4-25 µg/dL - RIA), aldosterone <1.0 ng/dL (1-16 ng/dL - RIA). Introduction of treatment with gluco- and mineralocorticoids achieved a significant improvement in physical activity and alleviation of hyperpigmentation.

Molecular analysis

Five members, in three generations - three brothers, the mother and the grandmother - of this family with AHC, underwent sequencing analysis for the detection of mutations in the DAX1 gene (Figure 1).

DNA samples were extracted from peripheral blood lymphocytes, and the entire coding region of the DAX1 gene was amplified by PCR using specific primers. Exon 1 was amplified with primers 1F - 5' - cac tgg gca gaa ctg ggc tac - 3' and 1R - 5' - cgc ccc tag ata ggc act ggc - 3' (Invitrogen™ Life Technologies, Carlsbad, CA, USA), using an initial denaturation step at 94°C for 5 min, followed by 40 cycles consisting of 94°C for 1 min, 65°C for 1.5 min and 72°C for 2 min, with a final extension step at 72°C for 10 min. Exon 2 was amplified with primers 2F - 5' - gct agc aaa gga ctc tgt ggt - 3' and 2R - 5' - cag ctc ttt att ctt ccc tca - 3', using an initial denaturation step at 94°C for 5 min, followed by 35 cycles consisting of 94°C for 1 min, 60°C for 1 min and 72°C for 2 min, with a final extension step at 72°C for 10 min. Both PCR reactions included 20 pmol of each primer, 200 µmol of each deoxynucleotide, 0.5 U of the *Taq* DNA polymerase, 10X buffer, 50 mmolar MgCl₂ (cat# N801-0055, GeneAmp - PCR reagent kit with AmpliTaq DNA polymerase Perkin Elmer, Branchburg, NJ, USA) and ddH₂O to obtain a final volume of 25 µL in a thermocycler (GeneAmp PCR System 9700, Applied Biosystem, Forster City, CA, USA). PCR products were, respectively, 1275 and 364 bp.

Direct sequencing analysis was performed by fluorescent dideoxynucleotides on an ABI PRISM 310 automatic sequencer, using internal primers for exon 1 (1iF - 5' - ggt aaa gag gcg cta cca ggc - 3' and 1iR - 5' - cgc ttg att tgt gct cgt gg - 3') and the same primers used for the PCR reaction for the exon 2 sequencing, following the manufacturer's protocol (ABI PRISM BigDye Terminator, version 3.1, Cycle Sequencing Kit, Applied Biosystem, Forster City, CA, USA).

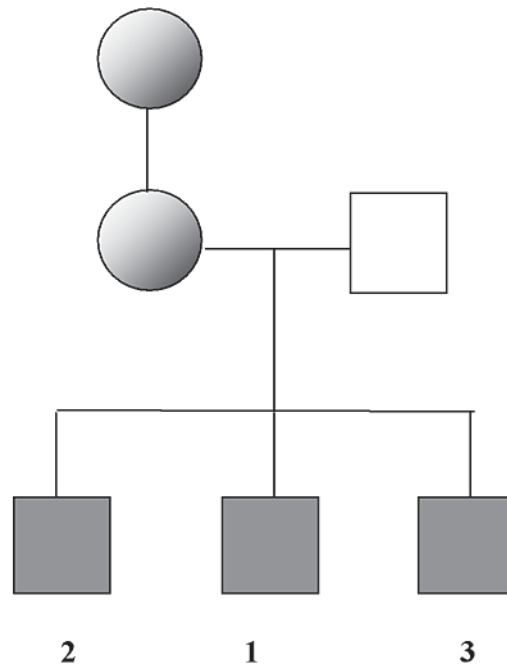

Figure 1. X-linked inheritance of adrenal hypoplasia congenita. Heterozygous carrier females are shown.

RESULTS

A summary of clinical and laboratory findings in this kindred with AHC is presented in Table 1.

All the evaluated members of this family showed the same mutation in exon 1 of the DAX1 gene, consisting of a C > T base change, determining a stop codon at position 359 (Q359X) (Figure 2). The mutated gene encodes a truncated protein missing a large portion of the terminal region, corresponding to the ligand-binding domain. This mutation position is graphically represented in Figure 3.

DISCUSSION

Most patients with DAX1 mutations present AHC, associated or not with hypogonadotropic hypogonadism. Time of appearance and characteristics of the first symptoms are variable and non-specific, resulting in increased difficulty for the diagnosis of these patients. Seminara et al., in 1999, described a wide phenotypic spectrum related to mutations in the DAX1 gene, including male infertility, sex reversion, delayed puberty in females, and different abnormalities of gonadotropin secretion, even within the same kindred. The possibility of X-linked transmission requires familial investigation once an index case is detected, allowing the early recognition of affected family members. To our knowledge, this is the first description of a family with three affected siblings.

Table 1. Clinical and laboratory features of the three brothers at diagnosis.

	Case 1 (index)	Case 2	Case 3
Age of AHC diagnosis	4 years	29 days of life	8 years, 9 months
Age of signs/symptoms	30 days of life	29 days of life	6 years
Symptoms/signs	Dehydration, vomiting, intubation, shock	Dehydration Loss of weight	Darkening of skin, weakness
Testis	Topic	Topic	Topic
Na (mEq/L)	133	114	133
K (mEq/L)	5.5	5.8	3.8
ACTH (pg/mL)	18,000	800	4000
Cortisol (µg/dL)	1.0	11	3.9

Reference ranges: ACTH = 10-60 pg/mL (chemoluminescence); cortisol = 5.4-25 µg/dL (RIA).
AHC = adrenal hypoplasia congenita.

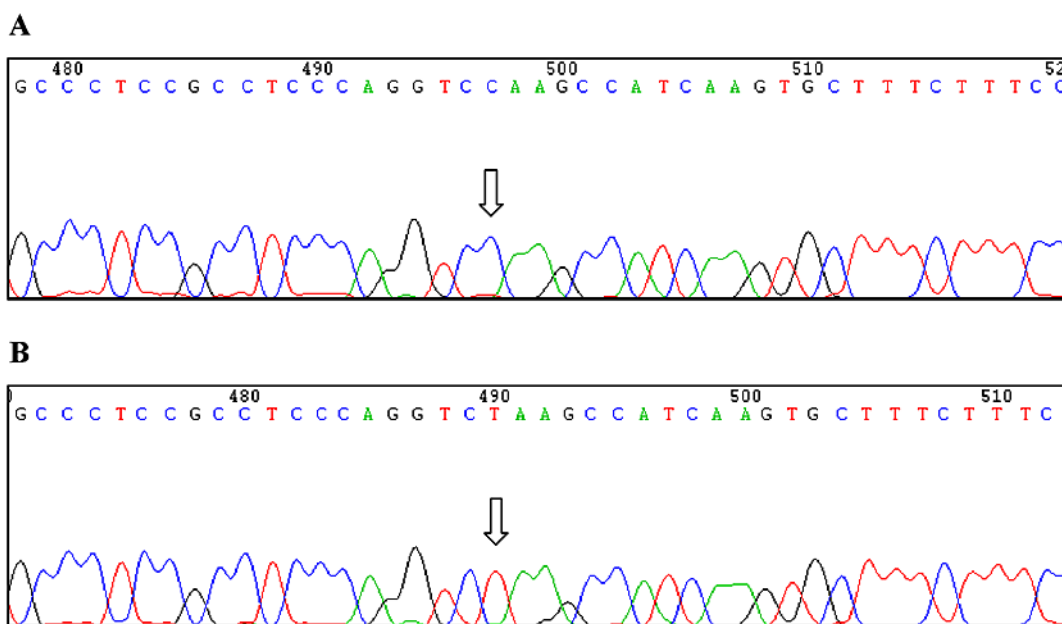
**Figure 2.** Sequence analysis of exon 1 of the DAX gene in: **A.** control - normal individual and **B.** an index case.

In the family described here, the detection of DAX1 gene mutation in case 1 allowed the diagnosis of his siblings. Curiously, as the investigation was ongoing, the mother was pregnant. At 29 days of life, the newborn lost weight and became dehydrated, and knowing his brother's disease, the diagnosis was established and treatment with gluco- and mineralocorticoid promptly initiated. After the detection of this second case, we investigated the older brother, confirming the same disease. Despite the mild clinical presentation, he was considered normal up to 8 years of age.

DAX-1 gene

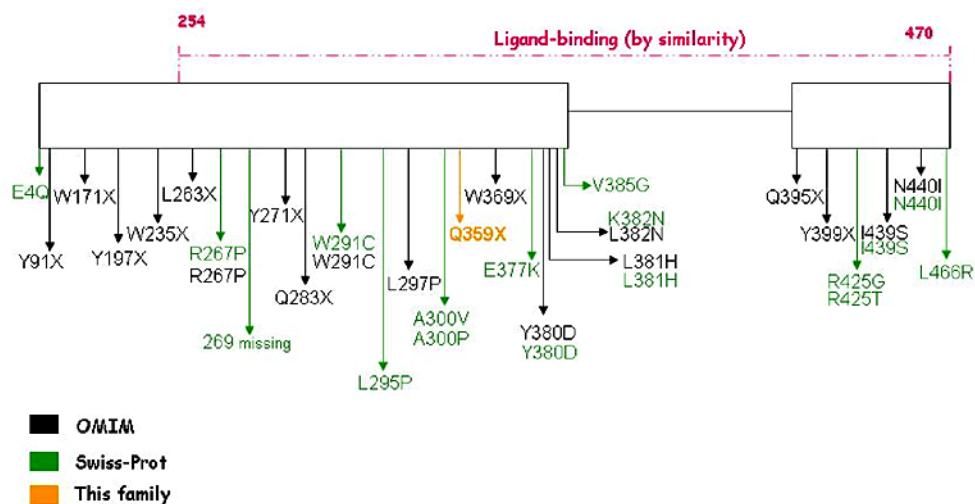

Figure 3. Location of mutation found in the three siblings, compared to other mutations described.

The impact of the diagnosis of an index case on other members of the family was also described by others. The family shown here demonstrates the phenotypic heterogeneity and absence of genotype/phenotype correlation in this condition. Despite this, if we look at the other families described in the literature, the majority of the kindreds present the same phenotype. Nakae et al. (1996) presented two brothers, 2 and 3 years of age, with a TRP291CYS mutation, both presenting generalized pigmentation and similar laboratory results (sodium, cortisol, aldosterone, and ACTH levels).

In one of the families studied by Habiby et al. (1996), two brothers with confirmed DAX1 mutations had similar presentation, in the first weeks of life. The kindred evaluated by Seminara et al. (1999) included two affected patients, a proband and his nephew, both with the same history of salt-wasting in the first month of life. Acherman et al., in 2000, described 2 brothers with an L381H mutation with diagnosis of adrenal insufficiency before the presentation of symptoms, after detecting the mutation in the older brother. Two other affected boys with AHC showed clinical presentation similar to that in our report; the younger brother was diagnosed in a salt-wasting crisis in the first month of life, and the older one was then evaluated, with 3 years of age, already presenting a milder waste of salt.

The molecular analysis confirmed a mutation in the DAX1 gene that generated a stop codon, leading to a truncated protein. Other DAX1 mutations were previously described in Brazil, one linked to adrenocorticotropin-dependent precocious puberty (Domenice et al., 2001), and a missense mutation (A300V) in a boy with AHC and hypogonadotropic hypogonadism (Correa et al., 2002).

Muscatelli et al. (1994) found that mutations in the DAX1 gene can determine both AHC and hypogonadotropic hypogonadism, suggesting that this gene is essential for the devel-

opment of a functioning hypothalamus-pituitary-gonadal axis. Not only adrenal symptoms can be variable with the same mutation. Habiby et al. (1996) studied the secretion of LH and FSH, and found a heterogeneous pattern of response to GnRH, suggesting that DAX1 mutations impair gonadotropin production acting at both hypothalamic and pituitary levels. Due to the ages of the three brothers shown here, a complete investigation of hypogonadotropic hypogonadism is not possible at this moment. However, we observed low-basal values of LH and FSH in case 1 (LH = 0.2 U/L, FSH = 0.49 U/L) and in case 3 (LH <0.1 U/L, FSH = 0.17 U/L).

After diagnosis, our patients received fludrocortisone and prednisolone (cases 1 and 3) and hydrocortisone acetate (case 2). All the symptoms disappeared and the boys are growing well.

In conclusion, we described three siblings with adrenal hypoplasia congenita, due to a novel mutation - Q359X - in the DAX1 gene. The detection of the mutation in the index case was helpful to investigate and diagnose the other two brothers. Treatment could be initiated immediately in an early and severe case (case 2) and in another mild case (case 3). Our data suggest a lack of genotype-phenotype correlation in cases of DAX1 mutations, requiring more careful evaluation of first-degree family members, independent of the presence of symptoms.

ACKNOWLEDGMENTS

We are grateful to the Support Center for Scientific Publications of Santa Casa de São Paulo, Faculty of Medical Sciences, for the editorial assistance.

REFERENCES

- Achermann JC, Silverman BL, Habiby RL and Jameson JL (2000). Presymptomatic diagnosis of X-linked adrenal hypoplasia congenita by analysis of DAX1. *J. Pediatr.* 137: 878-881.
- Correa RV, Domenice S, Estefan V, Villares SM, et al. (2002). Missense mutation a300v in the DAX1 gene in a Brazilian male with X-linked adrenal hypoplasia congenita and hypogonadotropic hypogonadism. *Case Rep. Clin. Pract. Rev.* 3: 144-147.
- Domenice S, Latronico AC, Brito VN, Arnhold IJ, et al. (2001). Adrenocorticotropin-dependent precocious puberty of testicular origin in a boy with X-linked adrenal hypoplasia congenita due to a novel mutation in the DAX1 gene. *J. Clin. Endocrinol. Metab.* 86: 4068-4071.
- Guo W, Burris TP, Zhang YH, Huang BL, et al. (1996). Genomic sequence of the DAX1 gene: an orphan nuclear receptor responsible for X-linked adrenal hypoplasia congenita and hypogonadotropic hypogonadism. *J. Clin. Endocrinol. Metab.* 81: 2481-2486.
- Habiby RL, Boepple P, Nachtigall L, Sluss PM, et al. (1996). Adrenal hypoplasia congenita with hypogonadotropic hypogonadism: evidence that DAX-1 mutations lead to combined hypothalamic and pituitary defects in gonadotropin production. *J. Clin. Invest.* 98: 1055-1062.
- Muscatelli F, Strom TM, Walker AP, Zanaria E, et al. (1994). Mutations in the DAX-1 gene give rise to both X-linked adrenal hypoplasia congenita and hypogonadotropic hypogonadism. *Nature* 372: 672-676.
- Nakae J, Tajima T, Kusuda S, Kohda N, et al. (1996). Truncation at the C-terminus of the DAX-1 protein impairs its biological actions in patients with X-linked adrenal hypoplasia congenita. *J. Clin. Endocrinol. Metab.* 81: 3680-3685.
- Seminara SB, Achermann JC, Genel M, Jameson JL, et al. (1999). X-linked adrenal hypoplasia congenita: a mutation in DAX1 expands the phenotypic spectrum in males and females. *J. Clin. Endocrinol. Metab.* 84: 4501-4509.
- Zanaria E, Muscatelli F, Bardoni B, Strom TM, et al. (1994). An unusual member of the nuclear hormone receptor superfamily responsible for X-linked adrenal hypoplasia congenita. *Nature* 372: 635-641.